

## Product Lineup

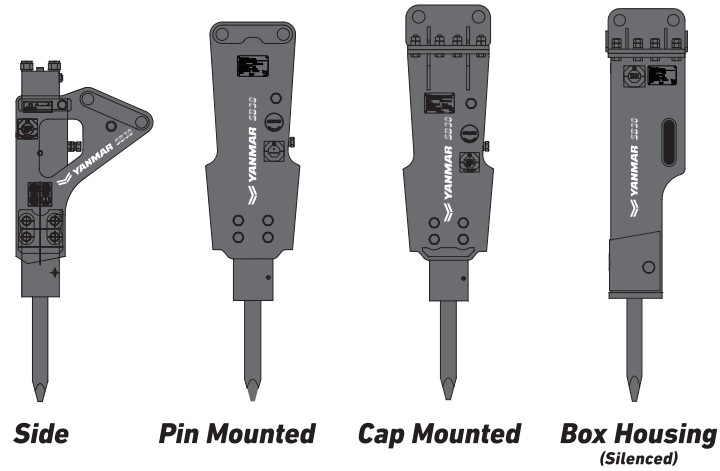

Tie-up Product

# Hydraulic Breaker

## For EXCAVATORS

### Hydraulic quick coupler makes changing attachments quick and easy.



\* The images shown here are for promotional purposes. \* The image may differ from the actual model on sale.  
\* The machine in the picture is equipped with optional parts. \* Ground the bucket when leaving the operator's seat.

#### Unattach bucket

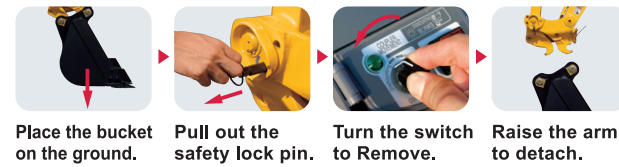

#### Attach bucket



### Chisel Selection

Thanks to strictly selected raw materials and advanced heat treatment system, we provide you with the most suitable and durable chisels for our breakers to be used on various applications such as trenching, demolition, road construction, quarrying, mining and etc.

Chisel type		Application
Moil point type		Standard chisel for multi-purpose, general use
Universal type		General demolition work : Masonry, concrete, etc.
H-Wedge type		Cross cutting work : Trenching, asphalt, concrete, etc.
V-Wedge type		Straight cutting work : Trenching, benching, asphalt, concrete, etc.
Flat type		Impact breaking : Primary and secondary rock breaking, etc.

### YANMAR CONSTRUCTION EQUIPMENT CO., LTD.

Overseas Sales Dept  
Marketing & Sales Div.  
1717-1, Oaza Kumano, Chikugo, Fukuoka 833-0055, Japan  
TEL. +81-942-53-5465  
FAX +81-942-53-5132  
yanmar.com

All data subject to change without notice.



# Features

## Side

### Stronger, Faster and more Durable

<Technical Specifications Side>

- Superb performance with high impact power, durability and reliability
- Less heat generation with SB percussion mechanism

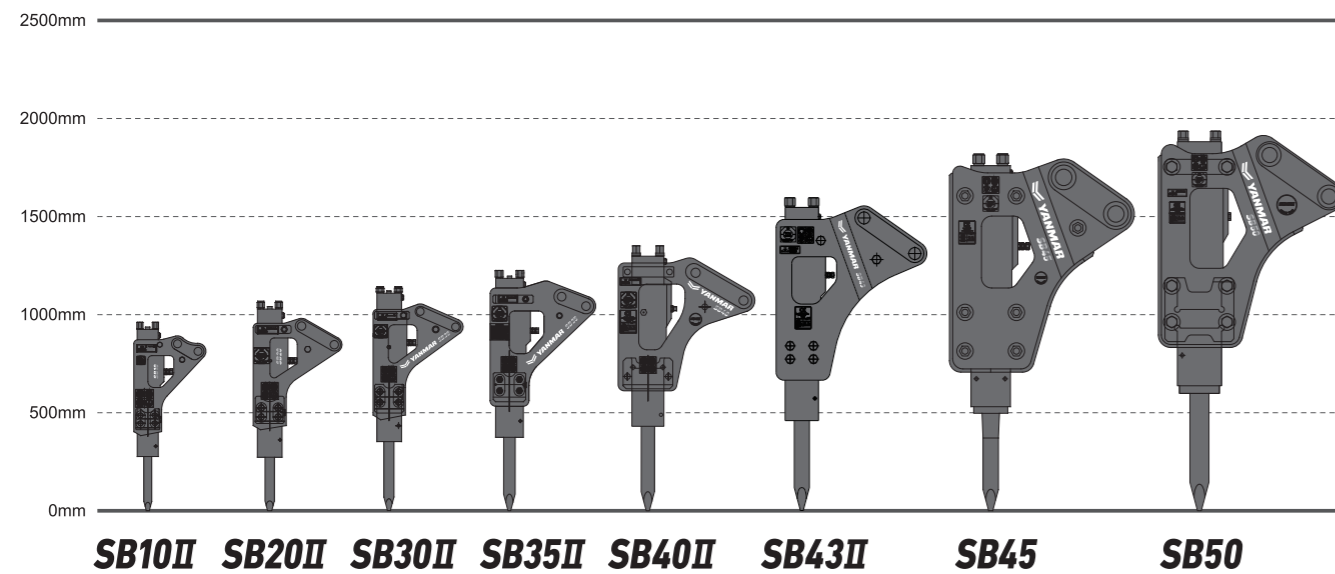

Description	Unit	SB10II	SB20II	SB30II	SB35II	SB40II	SB43II	SB45	SB50
Operating Weight	kg(lbs)	70(154)	90(198)	120(265)	180(397)	250(551)	380(838)	510(1,124)	765(1,687)
Overall Length	mm(inch)	972(38.3)	1,071(42.2)	1,147(45.2)	1,239(48.8)	1,349(53.1)	1,699(66.9)	1,827(71.9)	1,934(76.1)
Required Oil Flow	l/min (g/min)	15~30 (4.0~8.0)	20~40 (5.3~10.6)	25~50 (6.6~13.2)	30~60 (7.9~16.0)	40~70 (10.6~18.5)	50~90 (13.2~23.8)	60~100 (15.9~26.4)	80~110 (21.1~29.1)
Operating Pressure	kgf/cm <sup>2</sup> (PSI)	90~120 (1,280~1,707)	90~120 (1,280~1,707)	90~120 (1,280~1,707)	100~130 (1,422~1,849)	110~140 (1,560~1,991)	120~150 (1,707~2,134)	130~160 (1,849~2,276)	150~170 (2,134~2,418)
Impact Rate	bpm	800~1,400	700~1,200	600~1,100	500~1,000	500~900	400~800	400~800	350~700
Tool Diameter	mm(inch)	40(1.6)	45(1.8)	53(2.1)	60(2.4)	68(2.7)	75(3.0)	85(3.3)	100(3.9)
Applicable Model	-	SV08 ViO10/12-2 ViO17	ViO17 ViO20-6	ViO25-6 ViO30-6 ViO35-6	ViO30-6 ViO35-6 ViO50-6 ViO55-6	ViO45-6 ViO50-6 ViO55-6	ViO80-1 ViO82	ViO80-1 ViO82 SV100-2	SV100-2

## Pin Mounted

### Minimize maintenance costs, Maximize profits

<Technical Specifications Pin Mounted>

- Pin-mounted, light weight & compact designed side plates
- Superb performance with high impact power, durability and reliability
- Less heat generation with SB percussion mechanism

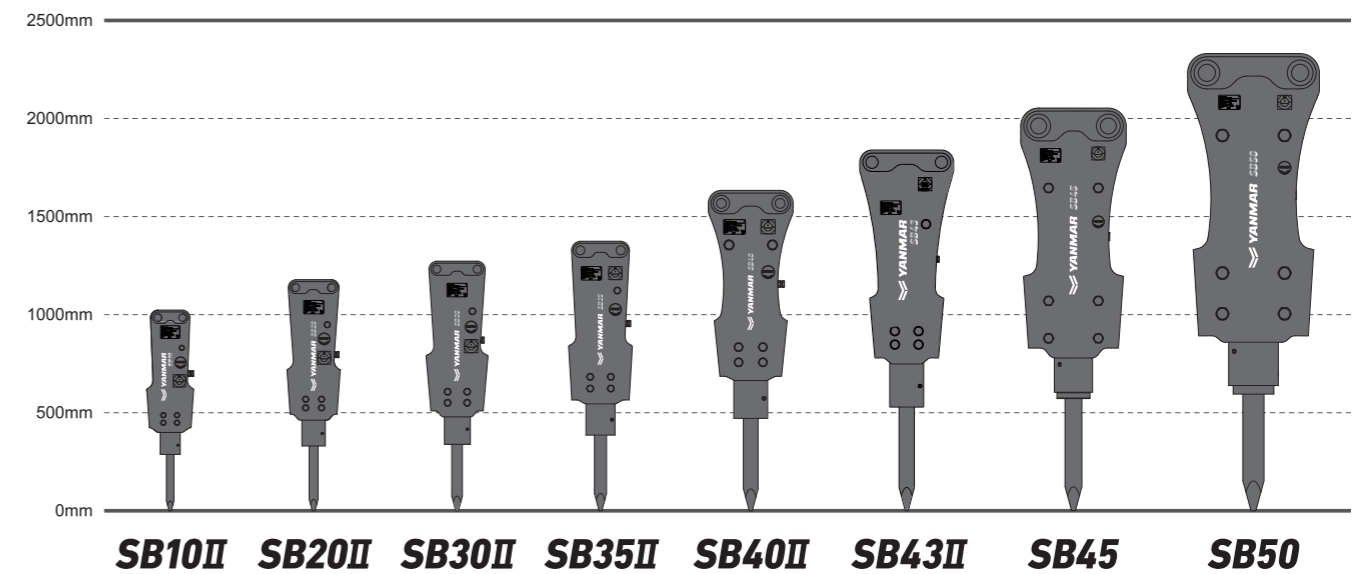

Description	Unit	SB10II	SB20II	SB30II	SB35II	SB40II	SB43II	SB45	SB50
Operating Weight	kg(lbs)	73(161)	100(220)	120(265)	189(417)	234(516)	375(827)	496(1,093)	743(1,638)
Overall Length	mm(inch)	1,072(42)	1,190(44)	1,287 (50.7~51.7)	1,382(54.4)	1,616(63.6)	1,767(69.6)	2,024(79.7)	2,150(84.6)
Required Oil Flow	l/min (g/min)	15~30 (4.0~8.0)	20~40 (5.3~10.6)	25~50 (6.6~13.2)	30~60 (7.9~16.0)	40~70 (10.6~18.5)	50~90 (13.2~23.8)	60~100 (15.9~26.4)	80~110 (21.1~29.1)
Operating Pressure	kgf/cm <sup>2</sup> (PSI)	90~120 (1,280~1,707)	90~120 (1,280~1,707)	90~120 (1,280~1,707)	100~130 (1,422~1,849)	110~140 (1,560~1,991)	120~150 (1,707~2,134)	130~160 (1,849~2,276)	150~170 (2,134~2,418)
Impact Rate	bpm	800~1,400	700~1,200	600~1,100	500~1,000	500~900	400~800	400~800	350~700
Tool Diameter	mm(inch)	40(1.6)	45(1.8)	53(2.1)	60(2.4)	68(2.7)	75(3.0)	85(3.3)	100(3.9)
Applicable Model	-	SV08 ViO10/12-2 ViO17	ViO17 ViO20-6	ViO25-6 ViO30-6 ViO35-6	ViO30-6 ViO35-6 ViO50-6 ViO55-6	ViO45-6 ViO50-6 ViO55-6	ViO80-1 ViO82	ViO80-1 ViO82 SV100-2	SV100-2

# Features

## Cap Mounted

### Minimize maintenance costs, Maximize profits

<Technical Specifications Cap Mounted>

- Cap-mounted light weight & compact designed side plates
- Superb performance with high impact power, durability and reliability
- Less heat generation with SB percussion mechanism

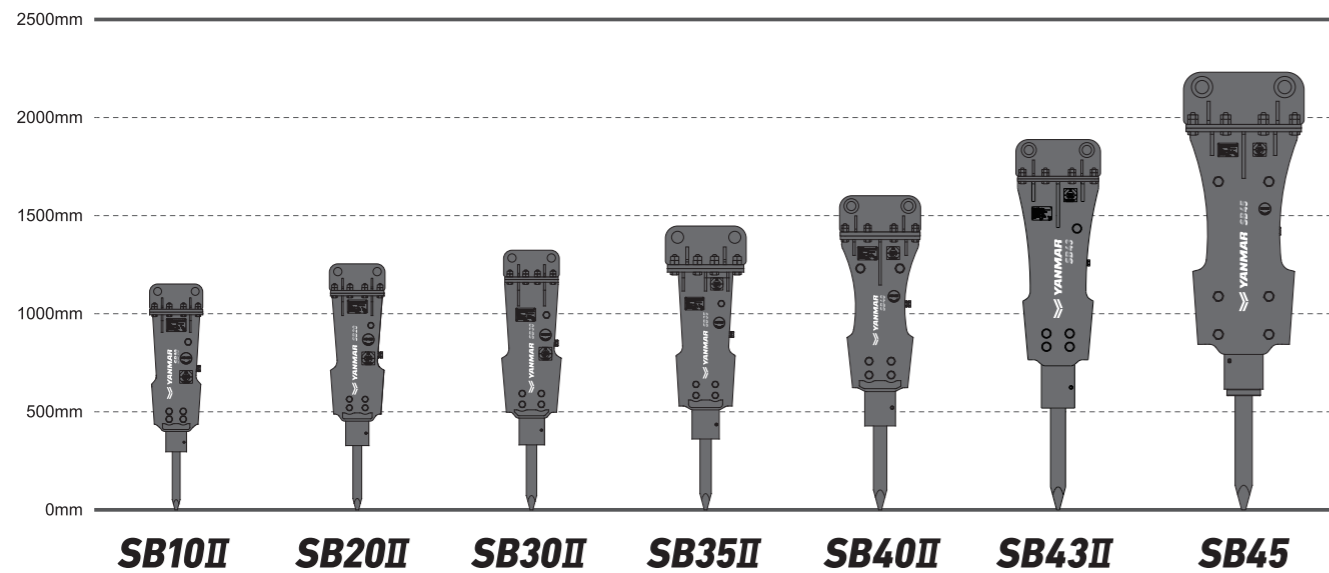

Description	Unit	SB10II	SB20II	SB30II	SB35II	SB40II	SB43II	SB45
Operating Weight	kg(lbs)	90(198)	110(244)	135(298)	204(450)	292(644)	380(838)	580(1,279)
Overall Length	mm(inch)	1,150(45.3)	1,254(49.4)	1,313 (50.7~51.7)	1,452(57.2)	1,602(63.1)	1,887(74.3)	2,225(87.6)
Required Oil Flow	l/min (g/min)	15~30 (4.0~8.0)	20~40 (5.3~10.6)	25~50 (6.6~13.2)	30~60 (7.9~16.0)	40~70 (10.6~18.5)	50~90 (13.2~23.8)	60~100 (15.9~26.4)
Operating Pressure	kgf/cm <sup>2</sup> (PSI)	90~120 (1,280~1,707)	90~120 (1,280~1,707)	90~120 (1,280~1,707)	100~130 (1,422~1,849)	110~140 (1,560~1,991)	120~150 (1,707~2,134)	130~160 (1,849~2,276)
Impact Rate	bpm	800~1,400	700~1,200	600~1,100	500~1,000	500~900	400~800	400~800
Tool Diameter	mm(inch)	40(1.6)	45(1.8)	53(2.1)	60(2.4)	68(2.7)	75(3.0)	85(3.3)
Applicable Model	-	SV08 ViO10/12-2 ViO17	ViO17 ViO20-6	ViO25-6 ViO30-6 ViO35-6	ViO30-6 ViO35-6 ViO50-6 ViO55-6	ViO45-6 ViO50-6 ViO55-6	ViO80-1 ViO82	ViO80-1 ViO82 SV100-2

## Box Housing(Silenced)

### Less noise, Less vibrations!

<Technical Specifications Box Housing(Silenced)>

- Fully enclosed housing with robust structure
- Service friendly design and less maintenance costs
- Vibration damping system
- Operator-friendly with low vibration

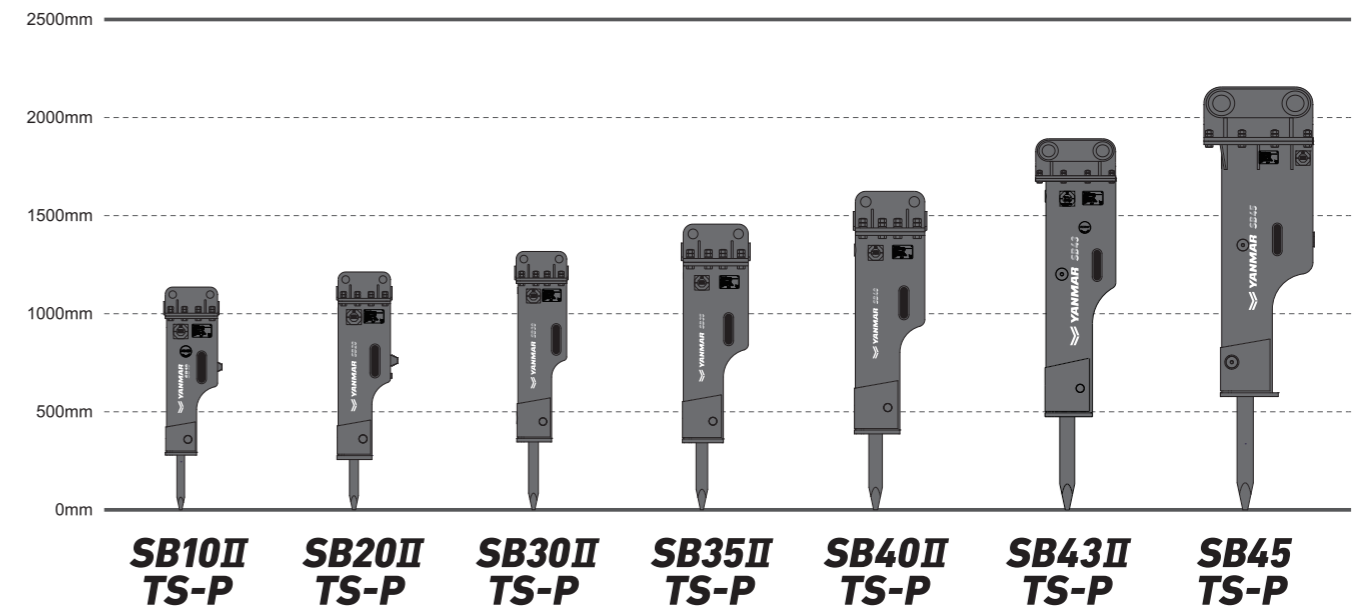

Description	Unit	SB10II TS-P	SB20II TS-P	SB30II TS-P	SB35II TS-P	SB40II TS-P	SB43II TS-P	SB45 TS-P
Operating Weight	kg(lbs)	102(225)	126(278)	152(335)	224(494)	295(650)	375(827)	571(1,259)
Overall Length	mm(inch)	1,135(44.7)	1,213(47.8)	1,317(51.9)	1,472(58.0)	1,620(63.8)	1,899(74.8)	2,161(85.0)
Required Oil Flow	l/min (g/min)	15~30 (4.0~8.0)	20~40 (5.3~10.6)	25~50 (6.6~13.2)	30~60 (7.9~16.0)	40~70 (10.6~18.5)	50~90 (13.2~23.8)	60~100 (15.9~26.4)
Operating Pressure	kgf/cm <sup>2</sup> (PSI)	90~120 (1,280~1,707)	90~120 (1,280~1,707)	90~120 (1,280~1,707)	100~130 (1,422~1,849)	110~140 (1,560~1,991)	120~150 (1,707~2,134)	130~160 (1,849~2,276)
Impact Rate	bpm	800~1,400	700~1,200	600~1,100	500~1,000	500~900	400~800	400~800
Tool Diameter	mm(inch)	40(1.6)	45(1.8)	53(2.1)	60(2.4)	68(2.7)	75(3.0)	85(3.3)
Applicable Model	-	ViO17	ViO17 ViO20-6	ViO25-6 ViO30-6 ViO35-6	ViO35-6 ViO50-6 ViO55-6	ViO45-6 ViO50-6 ViO55-6	ViO80-1 ViO82	ViO80-1 ViO82 SV100-2

# Precautions for safe operation

1 Proper position must be applied for an effective usage of breaking force. When position is incorrect, hammering energy of the piston is too weak to break rocks. Instead, hammering force applies shocks to the breaker body, breaker arm and boom of the base machine, thereby resulting in damage to those parts.

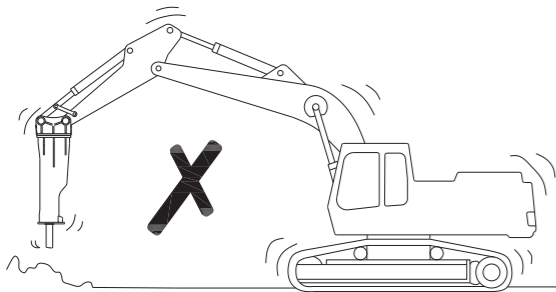

2 When position is excessive enough to break rocks with front of the base machine raised, the machine may suddenly tilt forward the moment rocks are broken. Then, the breaker body or the end of bracket may violently hit against rocks and result in damage.

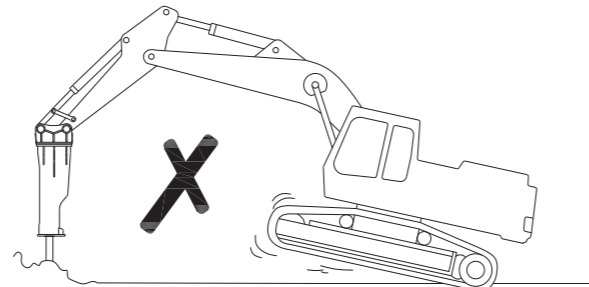

7 Do not operate breaker when all components except rod are immersed in water and mud. Underwater usage of the breaker will cause internal damage to the breaker.

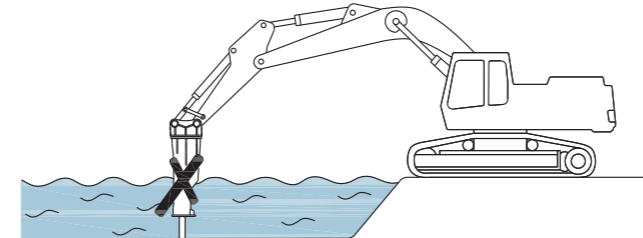

8 Do not allow the breaker to fall to a rock. Falling down the breaker will apply excessive force to the breaker or the carrier, causing damage to the parts of the breaker and carrier.

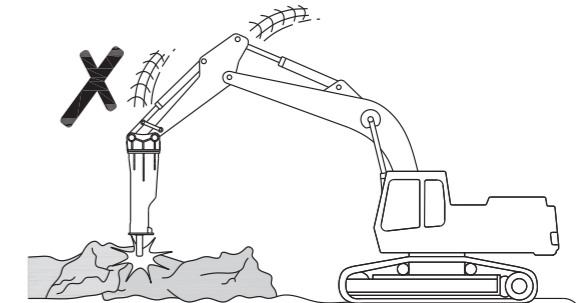

3 It is undesirable to carry out hammering under the below condition, because vibrations during hammering may be transmitted to tracks of the base machine. During hammering, however, proper position must be always applied to the breaker. Special care must be taken not to hammer under abnormal condition.

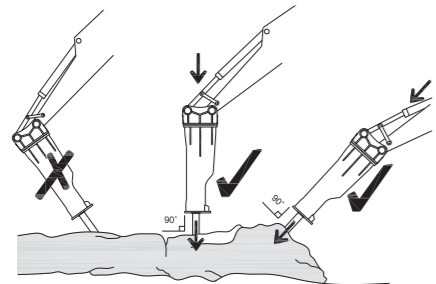

4 Apply same direction of boom force in line with the rod and place the rod in the rock with hammering surface as vertical as possible. If hammering surface is oblique, the rod may slip during hammering. This causes the rod to seize and to be broken and piston to be damaged. When breaking, fully stabilize the rod first and then select the point of a rock on which hammering can be performed in a stable condition.

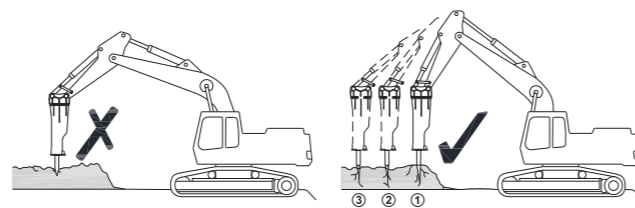

9 Breaking operation conducted at the stroke end (when the cylinder is extended or retracted to a maximum extent) of respective hydraulic cylinders of the carrier will lead to damage to the cylinders and other parts of the carrier.

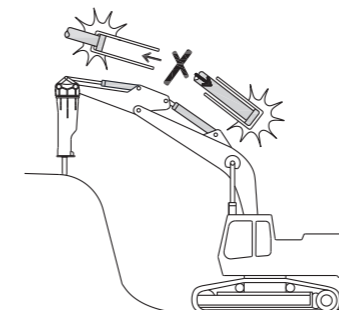

10 Lifting thing by hanging wire in the bracket or rod not only causes damage to the breaker but also is very dangerous.

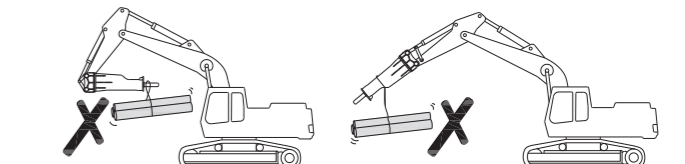

5 Rolling or falling a rock with the rod end or bracket side by using the boom or arm of the carrier as shown in the figure will result in breakage of the breaker mounting bolt or bracket, breakage and galling of rod, and damage to the arm and boom. Do not move rock. It is strictly prohibited to travel when the breaker is in the contact with rock.

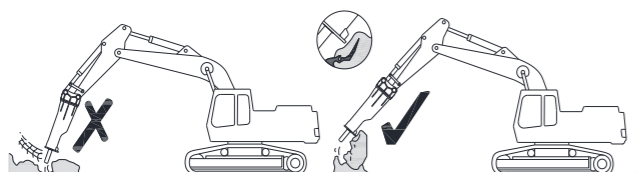

6 Do not use rod as a lever. Do not put the rod into a crack in rock and move the rod to and fro to breaker the rock, otherwise the rod will be broken or the bracket will be damaged.

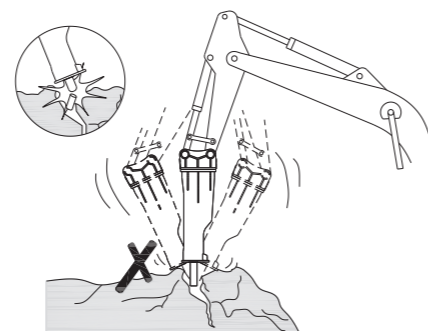

11 Warm-up of machine prior to operation

- Do not operate the machine right after starting the engine. Idle the machine for warm-up. Warm the hydraulic oil sufficiently especially in winter or in the cold place.
- Especially in winter, the machine's engine should be warmed up for 5 to 10 minutes 30~40°C (86~105°F) before breaker operation.
- When operating the hydraulic breaker, idle the engine and operate the hydraulic breaker with a light load.

12 Stop operation when hoses are vibrating abnormally. Check the hoses on the high pressure and low pressure sides of the breaker for abnormal vibration. If they are vibrating abnormally, contact the nearest YANMAR dealer.

13 Avoid blank hammering. Blank hammering accelerates wear and tear on breaker and carrier components and may result in failure of one or more components. Excessive blank hammering may be considered equipment abuse and may result in voiding warranties. In case of blank hammering, hammering sound changes.

14 Operate the breaker at proper engine speed. Break rocks at the specified engine speed. Raising engine speed more than necessary does not strengthen hammering force but increase oil temperature to the detriment of piston and valve.